

—  
US BROCHURE

# Circuit protection according to UL 489 and UL 1077





---

# Table of contents

<b>004–007</b>	<b>Introduction</b>
<b>008–009</b>	<b>Product selection guide</b>
<b>010–017</b>	<b>Accessories</b>
<b>018</b>	<b>Trip curve information</b>

---

## ABB miniature circuit breakers

The first of its kind in 1923, and still the best today. We didn't just change the market — we created it.

In 1923, Hugo Stotz made history. He invented a new and innovative circuit breaker that would revolutionize the world of electrical installation and safety.

The combination of a thermal and magnetic trip unit in a single device became the “thermal-electromagnetical circuit breaker,” that was then patented in 1924 as the first-ever resettable fuse. Because it could simply be screwed into usual fuse sockets, it was a huge success for the company, which has now been located in Germany for over 120 years.

This revolutionary circuit breaker was able to interrupt an electrical circuit in case of overload and was reclosable, whereas the metal wire in previous fuses would melt when too much current passed through it and had to be replaced.

Another key benefit to this pioneering design was that no electrician was needed to change fuses any more — even an unskilled person could do it. To this day, that is still the case.

### Then

In 1923, Hugo Stotz combined a thermal and a magnetic trip unit in a single device that could be screwed into regular fuse sockets. Stotz's invention opened a new world in electrical installation.

### Now

The latest generation of ABB mini circuit breakers (MCBs) provides the highest safety solutions for all types of electrical protection — and meets all relevant standards worldwide.

### System pro M compact™ MCBs

Miniature circuit breakers protect installations against overload and short circuit to ensure reliability and safety for operations. ABB MCBs feature current-limiting technology, which reduces the risk of arc flash and increases protection of connected cables and loads.

ABB MCBs are available with a wide variety of accessories, thus providing solutions for all types of applications.

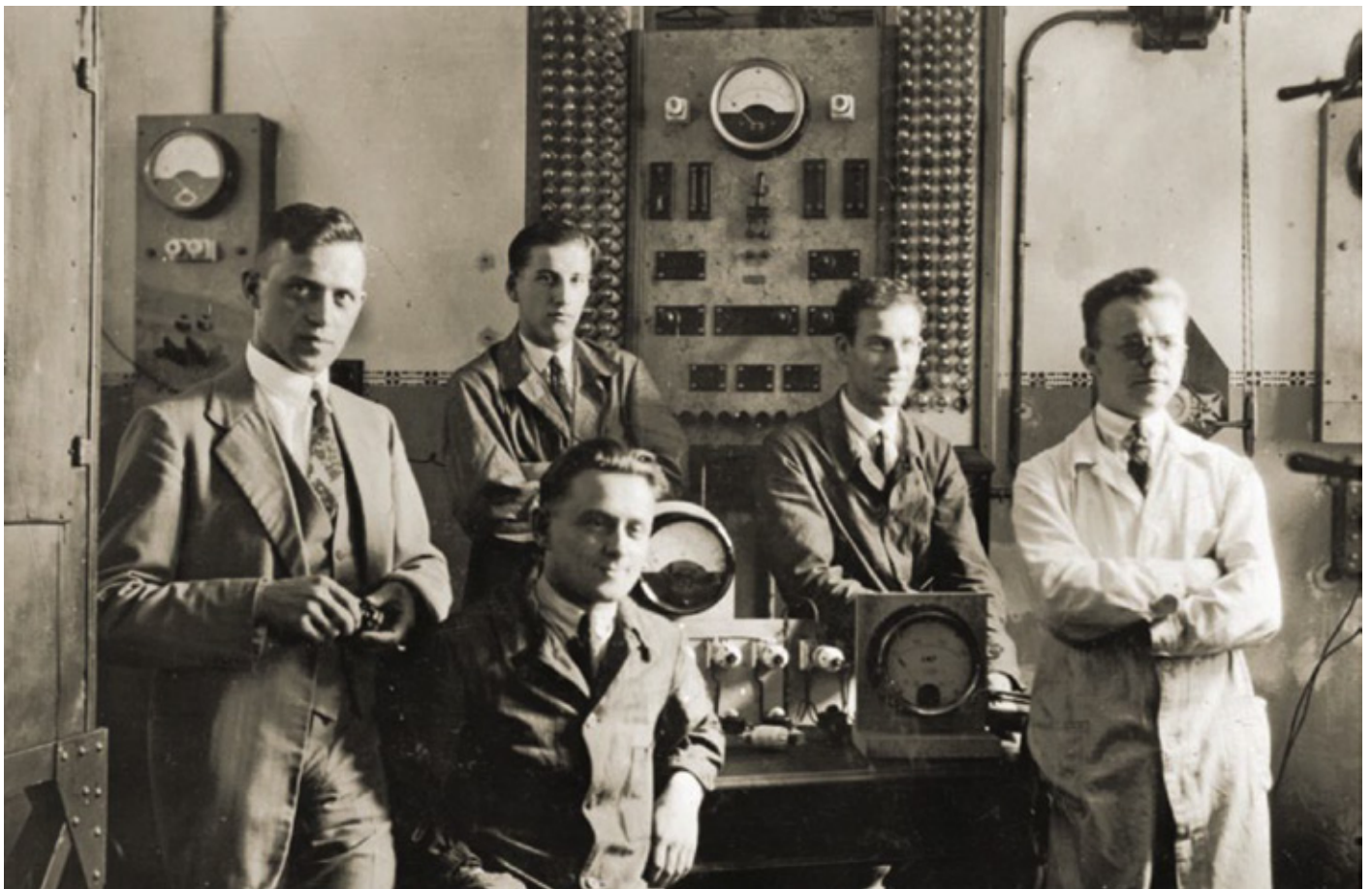

## Quality and sustainability

Our MCBs are built to last. We achieve this through an uncompromising commitment to quality. We use only the best components and materials. All materials comply with EU (RoHS, REACH) standards for sustainability and are halogen-free. Every unit is inspected three times before it leaves our facilities.

Our reputation for innovation, quality and performance is built into every ABB circuit breaker with these patented features:

### Terminal

Extended size with insulation for IP20 protection and new pressure plate for improved conductor connection — easier to handle, safer to use

### Switching mechanism

New design and assembly increases reliability of triggering — even under tough conditions

### Contact design

With a trip-free snap-action mechanism for improved arc movement and safe, optimized switching

### Tripping device

Optimized arc extinguishing system improves safety

Patented twin terminals with captive screws add comfort and safety

Product code identifies basic technical specs

Patented tripping device ensures uncompromised safety

Contact-position indicator with direct contact connection clearly indicates position for extra safety

Simple switch mechanism provides immediate system availability after a fault

Laser printing resists scratches and solvents

Unit performs at its high rated voltage

Patented housing design offers environmental friendliness and optimized performance

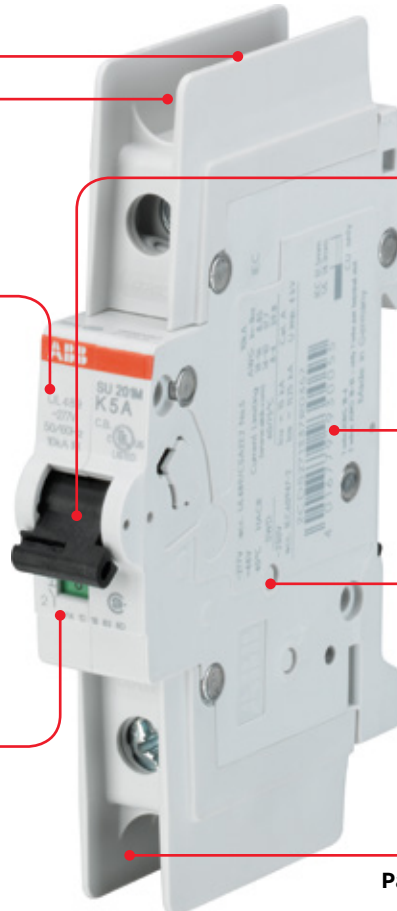

## The details make the difference

Miniature circuit breakers made by ABB

System pro M compact offers a complete range of first-class quality products including a variety of miniature circuit breakers that provide the right solution when both size and performance matter.

- 01 Patented IP20 touch-safe terminals
- 02 Red/green indicator shows actual position of contacts
- 03 Approvals printed on the dome
- 04 Safe, easy and fast connection with busbars (fixed length or cuttable to length)
- 05 Various cable combinations can be used with the dual terminals
- 06 For interrupt ratings up to 50 kA (S800 series)

### Patented IP20 finger-safe terminals

Extended size with insulation for IP20 protection and new pressure plate for improved conductor connection available for the S200 series. Additionally, our innovative ring-lug terminals are available (SU200MR and S200MR). MCBs of the S800U series are equipped with a convertible lug or ring-lug terminal.

### Contact position indication

All System pro M compact MCBs are equipped with real contact position indication (CPI). This allows for quick identification of the MCB's state, on or off, if maintenance is required. Working together, both the position of the toggle and the color of the CPI offer clear indication of the MCB's contact position, providing additional safety. If an event has occurred, the MCB provides reliable information on its state.

### Approvals printed on the dome

SU200M MCBs comply with UL489/CSA 22.2 No. 5 and carry approvals for other relevant markets or segments in which they may be used. For ease of identification, certification markings are printed on the dome and side of the MCB.

### Comfort connection

Dedicated busbars are available, depending on the application. The new cut-to-length UL Vario busbar is available for the SU200M. A special ring-lug busbar for the SU200MR and S200M was designed to fit these devices.

### Maximum flexibility

The dual terminals with two separate slots allow connection of busbars and cables in separate spots. They also allow for installation of up to four cables in each terminal (2+2).

### Extra power needed?

S800 series MCBs offer high performance in terms of current, voltage and short circuit interrupt ratings.



01



02



03



04



05



06



—  
MCB factory in Heidelberg, Germany



**Logout/tag out device**

Since safety is always at the forefront, the new S 200-LOTO devices can be added for use in a lockout-tag out program. The S 200-LOTO device is available in single- and multi-pole versions.



**Patented housing design**

The SU200M range uses the latest halogen-free thermoplastic, making it possible to recycle the whole MCB and reduce environmental pollution.

—  
Fully automated production/assembly with 100% quality control

## Product selection guide

MCBs per UL 489 / CSA 22.2 No. 5 — SU200M / SU200ML / SUP200M / SU200MR / S200UDC / S800U

### UL 489

This standard covers circuit breakers (molded-case circuit breakers for protection of service entrance, feeder and branch circuits). These circuit breakers are specifically intended to provide service entrance, feeder and branch circuit protection in accordance with the National Installation Codes in Annex B, Ref. No.1. This standard also covers instantaneous-trip circuit breakers (circuit interrupters) specifically intended for use as part of a combination motor controller in accordance with the National Installation Codes in Annex B, Ref. No. 1

### UL 489

	SU200M	SU200ML	SUP200M	SU200MR	S200UDC	S800U
Voltage	480Y/277 V AC up to 40 A (Z and C trip curves) 480Y/277 V AC up to 35 A (K trip curve) 240 V AC up to 63 A (all trip curves) 48/96 V DC up to 63 A (1-/2-pole, all trip curves)	240 V AC	480Y/277 V AC	480Y/277 V AC (up to 35 A) 240 V AC (up to 63 A)	125/250 V DC (1-/2-pole) <40 A 60/125 V DC (1-/2-pole) >40 A	240 V AC
Amperage	0.5 to 63 A (C, Z curve) 0.2 to 63 A (K curve)	0.5 to 63 A (C, Z curve) 0.2 to 63 A (K curve)	1 to 40 A (C, Z curve) 1 to 35 A (K curve)	up to 63 A	up to 63 A	10–100 A
Number of poles	1, 2, 3, 4	1, 2, 3, 5	1,2,3	1, 2, 3, 4	1, 2	1, 2, 3, 4
Trip curves	C, K, Z	C, K, Z	C, K, Z	K	Z, K	Z, K
Short circuit interrupt rating	10 kA	14 kA	14 kA	10 kA	14 kA	30 kA (1-pole), 50 kA (multipole)
Ambient temperature	-25 °C to +55 °C (-40 °C to +70 °C)	-25 °C to +55 °C (-40 °C to +70 °C)	-25 °C to +55 °C (-40 °C to +70 °C)	-25 °C to +55 °C (-40 °C to +70 °C)	-25 °C to +55 °C (-40 °C to +70 °C)	-25 °C to +55 °C (-40 °C to +70 °C)
Calibration temperature	40 °C	–	40 °C	40 °C	25 °C	25 °C
Mounting position	Any	Any	Any	Any	Any	Any
Mounting/ mounting position	35 mm DIN rail, front panel/dead front (with accessories)/any	35 mm DIN rail, front panel/dead front (with accessories)/any	35 mm DIN rail, front panel/dead front (with accessories)/any	35 mm DIN rail, front panel/dead front (with accessories)/any	35 mm DIN rail, front panel/dead front (with accessories)/any	35 mm DIN rail/any
Cable size	18–4 AWG	18–4 AWG	18–4 AWG	18–4 AWG	18–4 AWG	18–4 AWG



SU200M



SU200MR



S200UDC



S800U



## Product selection guide

MCBs per UL1077 / CSA 22.2 No. 235 — ST200M / S200MUC / S200MR / S800C / S800S

### UL 1077

This standard covers supplementary protectors for use as an additional level of protection where branch circuit protection is already provided or not required. Typical applications are in control circuits or within appliances. Compliance with this standard is acceptable for use as a component of an end product.

### UL 1077

	ST200M	S200MUC	S200MR	S800C	S800S
Voltage	480Y / 277 V AC; 60 V DC (1p) / 125 V DC (2 to 4p)	250 / 500 V DC; 480Y / 277 V AC	480Y / 277 V AC	480Y/277 V AC 125 V DC per pole, 500 V DC max.	600Y/347 V AC
Amperage	0.5–63 A	0.2–63 A (K curve) 0.5–63 A (C, Z curve) 6–63 A (B curve)	0.2–63 A	10–100 A	6–63 A
Poles	1P, 2P, 3P, 4P 1P+N, 3P+N	1P, 2P, 3P, 4P	1P, 2P, 3P, 4P	1P, 2P, 3P, 4P	1P, 2P, 3P
Trip curves	B, C, D, K, Z	B, C, K, Z	K	B, C, D, K	B, C, D, K
SCCR rating	Up to 10 kA (AC); 10 kA (DC)	6 kA (AC); 10 kA (DC)	10 kA		30 kA at 240 V AC 14 kA at 480Y/277 V AC 6 kA at 600Y/347 V AC
Ambient temperature	-25 °C to 55 °C	-25 °C to 55 °C	-25 °C to 55 °C	-25 °C to 60 °C	-25 °C to 60 °C
Mounting position	Any	Any	Any	Any	Any
Terminal	Failsafe bidirectional cylinder lift	Failsafe bidirectional cylinder lift	Insulated ring-lug terminal; 12.2 mm (W) x M5 (int. dia.)	Cage or ring tongue terminal (convertible)	Cage or ring tongue terminal (convertible)
Wire range	18–4 AWG	14–4 AWG	18–4 AWG	14–2 AWG (up to 30 A) 8–1 AWG (40 to 100 A)	14–2 AWG (up to 30 A) 8–1 AWG (40 to 100 A)



ST200M



S200MUC



S200MR



S800S/C

## Accessories

The System pro M compact offers all of the essential accessories such as shunt trips, undervoltage trips and auxiliary and signal contacts.

### Auxiliary contacts

The switching position of the auxiliary contact is dependent upon the toggle position of the MCB (on/off). Being coupled to the switching mechanism, the auxiliary contact is used to indicate the state of the MCB.

### Signal contact/bell alarm

In the event of an overload or short circuit, the signal contact will indicate that the MCB has tripped. When the MCB is operated manually, the signal contact will not provide an indication, as the signal contact is coupled to the trip mechanism of the MCB. The signal contact also allows for resetting of the signal contact independently of the MCB.

### Shunt trip

When applying a voltage to the solenoid, this accessory allows remote opening of the device. Two different models are available for both AC and DC control voltages.

### Busbar systems

Using the patented twin-terminal design, busbars can be connected even after the device has been installed. For ring-lug MCBs, a newly designed busbar is available.

### Lockout / tag out device

Since safety is always at the forefront, the new S200-LOTO devices can be added for use in a lockout-tag out program. The S200-LOTO device is available in single- and multi-pole versions.

### Undervoltage release

Protection of the load in the event of a voltage drop (between 70% and 35% of its rated value); positive safety (device is tripping when the voltage is disconnected); emergency stop by means of a button.

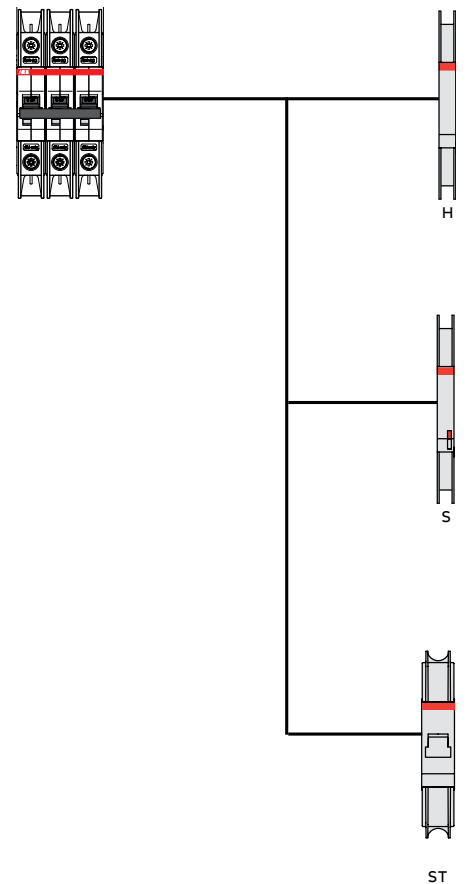

### SU200M, SU200MR, S200UDC

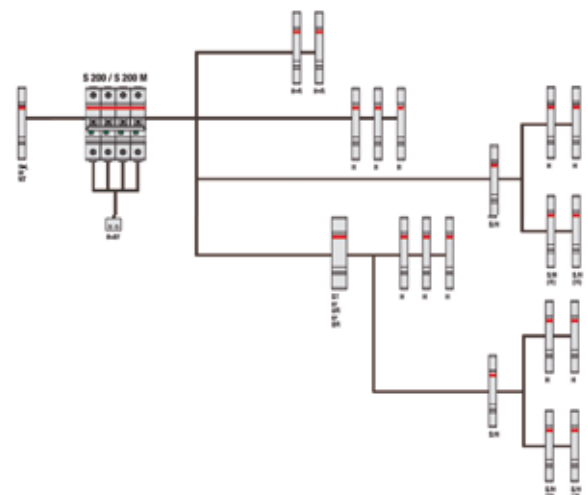

### ST200M, S200MUC, S200MR





## Accessories for UL 489 applications

Product	Product details	Type code
	<b>Auxiliary contact and signal contact</b>	
	Auxiliary contact (switch)	S2C-H6RU
	Signal contact (bell alarm)	S2C-S6RU
	<b>Shunt trip</b>	
	Rated voltage 12–60 V AC/DC	S2C-A1U
	Rated voltage 110–415 V AC, 110–250 V DC	S2C-A2U
	<b>Lockout / tag out device</b>	
	Single-pole MCBs	S2C-LOTO-S
	Multi-pole MCBs	S2C-LOTO-M

For additional busbars and accessories, please refer to the main catalog.

## Accessories for UL 489 applications

Product	Product details	Type code
	<b>Busbar</b>	
	(no. phases, no. of pins, cross section)	
	<b>Cuttable busbar</b>	
	1 Ph., 57 pins, 25 sq mm	PS 1/57/25 BP C
	1 Ph., 37 pins, 25 sq mm	PS 1/37/25 BP C
	2 Ph., 56 pins, 25 sq mm	PS 2/56/25 BP C
	2 Ph., 46 pins, 25 sq mm	PS 2/46/25 BP C
	3 Ph., 57 pins, 25 sq mm	PS 3/57/25 BP C
	3 Ph., 48 pins, 25 sq mm	PS 3/48/25 BP C
	3 Ph., 39 pins, 25 sq mm	PS 3/39/25 BP C
	<b>Accessories for cuttable busbars</b>	
	Endcap	PS-END3BP-C
	<b>Non-cutttable busbar</b>	
	1 Ph., 6 pins, 16 sq mm	PS 1/6/16BP
	1 Ph., 12 pins, 16 sq mm	PS 1/12/16BP
	1 Ph., 18 pins, 16 sq mm	PS 1/18/16BP
	2 Ph., 6 pins, 16 sq mm	PS 2/6/16BP
	2 Ph., 12 pins, 16 sq mm	PS 2/12/16BP
	2 Ph., 18 pins, 16 sq mm	PS 2/18/16BP
	3 Ph., 6 pins, 16 sq mm	PS 3/6/16BP
	3 Ph., 12 pins, 16 sq mm	PS 3/12/16BP
	3 Ph., 18 pins, 16 sq mm	PS 3/18/16BP
	<b>Ringlug busbar</b>	
	1 Ph., 57 ring-lugs, 25 sq mm	PS 1/57/25 BP CR
	1 Ph., 37 ring-lugs, 25 sq mm	PS 1/37/25 BP CR
	2 Ph., 56 ring-lugs, 25 sq mm	PS 2/56/25 BP CR
	2 Ph., 46 ring-lugs, 25 sq mm	PS 2/46/25 BP CR
	3 Ph., 57 ring-lugs, 25 sq mm	PS 3/57/25 BP CR
	3 Ph., 48 ring-lugs, 25 sq mm	PS 3/48/25 BP CR
	3 Ph., 39 ring-lugs, 25 sq mm	PS 3/39/25 BP CR

For additional busbars and accessories, please refer to the main catalog.

## Accessories for UL 489 and UL 1077 applications

### Rotary operating mechanism

For through-the-door operation with a pistol or selector handle in applications where the breaker is also used as a main disconnecting means (disconnect switch).



Description	Cat. no.
Rotary handle mechanism can be used with any 5 or 6 mm shaft and any kind of handle (for example, selector handles, pistol handles)	S2C-DH

### Filling piece

For heat dissipation of closely mounted devices that generate much heat. Width 8.75 mm, as spacer, two different heights, breakable, for DIN rails according to DIN EN 60 715, 35 x 7.5 mm.



Product description	Weight 1 piece kg	Pack unit pc.	Cat. no.
Filling piece	0.01	25	SZ-FST 2

### False poles







	Weight 1 piece kg	Pack unit pc.	Cat. no.
False pole — 1 module	0.01	100	FP1
Support for false pole	0.012	10	SFP

### Flanges



	Weight 1 piece kg	Pack unit pc.	Cat. no.
Flange for rear board mounting 1 module — IP40	0.040	1	ME 1
Flange for rear board mounting 2 modules — IP40	0.045	1	ME 2
Flange for rear board mounting 3 modules — IP40	0.055	1	ME 3
Flange for rear board mounting 4 modules — IP40	0.060	1	ME 4
Flange for rear board mounting 6 modules — IP40	0.070	1	ME 6
Flange for rear board mounting 8 modules — IP40	0.080	1	ME 8

## Accessories for UL 1077 applications

Product	Product details	Type code
	<b>Signal / auxiliary contacts mounting on the left side</b>	
	Signal contact/ auxiliary switch 1 CO	S2C-S/H6R
	Auxiliary contact 1 CO	S2C-H6R
	Auxiliary contact 1 NO/1NC	S2C-H6-11R
	Auxiliary contact 2 NO	S2C-H6-20R
	Auxiliary contact 2 NC	S2C-H6-02R
	<b>Auxiliary contacts mounting on the left side</b>	
	Auxiliary contact 1 NO/1NC	S2C-H11L
	Auxiliary contact 2 NO	S2C-H20L
	Auxiliary contact 2 NC	S2C-H02L
	<b>Bottom-fitted auxiliary contact</b>	
	Auxiliary contact 1 NC	S2C-H01
	Auxiliary contact 1 NO	S2C-H10
	<b>Shunt trip</b>	
	Rated voltage AC/DC 12...60 V	S2C-A1
	Rated voltage AC 110...415 V/DC 110...250 V	S2C-A2
	<b>Undervoltage releases</b>	
	Rated voltage 12 V DC	S2C-UA 12 DC
	Rated voltage 24 V AC	S2C-UA 24 AC
	Rated voltage 24 V DC	S2C-UA 24 DC
	Rated voltage 48 V AC	S2C-UA 48 AC
	Rated voltage 48 V DC	S2C-UA 48 DC
	Rated voltage 110 V AC	S2C-UA 110 AC
	Rated voltage 110 V DC	S2C-UA 110 DC
	Rated voltage 230 V AC	S2C-UA 230 AC
	Rated voltage 230 V DC	S2C-UA 230 DC
Rated voltage 400 V AC	S2C-UA 400 AC	

## Accessories for UL 1077 applications

Busbars PS...CB and accessories according to UL 508 for MCBs ST200M and S200MUC

Busbars type PS...CB are used for quick and easy line side wiring of miniature circuit breakers according to UL 1077 as well as fuse disconnectors E90. The entire product line, including the accessories, is approved according to UL 508 (cULus) and can be used for applications in supplementary protection circuits in UL and CSA markets

### Application and installation

- cULus listing according to UL 508
- For UL and CSA applications
- For use with MCB types according UL 1077, ranges S200, S200M, S200P, S200MUC, S200MTUC, ST200M and fuse disconnectors E90
- Quick and easy installation
- Can be cut off to the required length
- Suitable for AC and DC applications
- Global use in UL, CSA and IEC markets

### Product range

- 1-, 2-, 3-pole types
- 18 mm<sup>2</sup> and 25 mm<sup>2</sup> cross section
- For MCBs with or without auxiliary contact
- Touch-safe thanks to end caps and electric shock-protection caps installed over unused busbar pins
- Rated current max. 200 A
- Rated voltage according to UL
  - 1-phase: 1,000 V AC/DC
  - 2-/3-phase: 600 V AC/DC
- End caps, electric shock-protection caps and feeder terminals as accessories

### Busbars suitable for cutting

	Phases	mm <sup>2</sup>	No. of pins
	<b>1-phase busbars, pin distance 17.6 mm, end caps PS-END 1 CB</b>		
	1	18	57
	1	25	57
	<b>1-phase busbars, connection of 1-pole devices with auxiliary, end caps PS-END 1 CB</b>		
	1	18	37
	1	25	37
	<b>2-phase busbars, pin distance 17.6 mm, end caps PS-END 3 CB</b>		
	2	18	56
	2	25	56
	<b>2-phase busbars, connection of 2-pole devices with auxiliary, end caps PS-END 3 CB</b>		
	2	18	46
	2	25	46
	<b>3-phase busbars, pin distance 17.6 mm, end caps PS-END 3</b>		
	3	18	57
	3	25	57
	<b>3-phase busbars, connection of 3-pole devices with auxiliary, end caps PS-END 3 CB</b>		
	3	18	48
	3	25	48
<b>3-phase busbars, connection of 1-pole devices with auxiliary, end caps PS-END 3 CB</b>			
3	18	39	
3	25	39	

## Accessories for S800 series MCBs

### Auxiliary contact S800-AUX

The switching position of the auxiliary contact is dependent upon the toggle position of the MCB (on/off). Being coupled to the switching mechanism, the auxiliary contact is used to indicate the state of the MCB.

### Auxiliary / signal contact S800-AUX/ALT

The device has an integrated auxiliary contact (see above) and a signal contact. In the event of an overload or short circuit, the signal contact will indicate that the MCB has tripped. When the MCB is operated manually, the signal contact will not provide an indication, because the signal contact is coupled to the trip mechanism of the MCB. The signal contact also allows for resetting of the signal contact independently of the MCB.

### Shunt trip

When applying a voltage to the solenoid, this accessory allows remote opening of the device. Two different models are available for both AC and DC control voltages.

### Under-voltage release

Protection of the load in the event of a voltage drop (between 70% and 35% of its rated value); positive safety (device is tripping when the voltage is disconnected); emergency stop by means of a button.

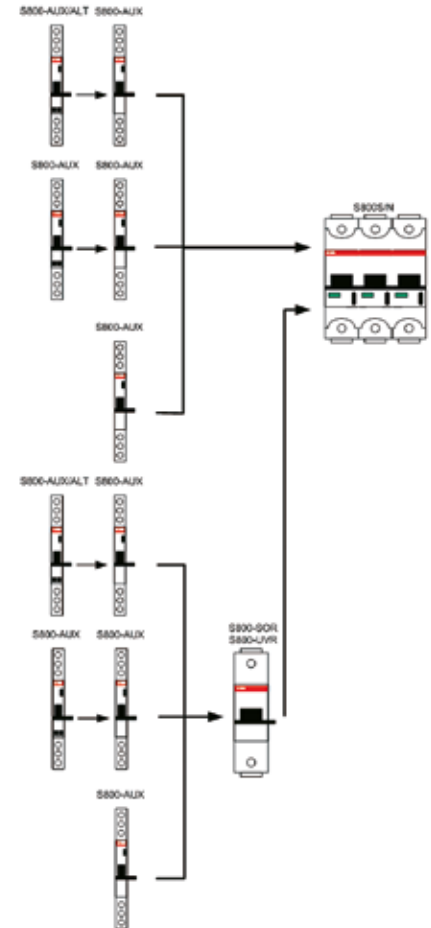

### Combination of auxiliary elements and S800





## Accessories for S800 series MCBs

UL 489 / CSA 22.2 No. 5

Product	Product details	Type code
	<b>Auxiliary contact, combined auxiliary and signal contact</b>	
	Auxiliary contact	S800-AUX
	Combined auxiliary and signal contact	S800-AUX / ALT
	<b>Shunt operation releases</b>	
	Nominal voltage 12 V AC/DC	S800-SOR12
	Nominal voltage 24 V AC/DC	S800-SOR24
	Nominal voltage 48...130 V AC/DC	S800-SOR130
	Nominal voltage 110...250 V AC/DC	S800-SOR250
	<b>Undervoltage releases</b>	
	Nominal voltage 24...36 V AC/DC	S800-UVR36
	Nominal voltage 48...60 V AC/DC	S800-UVR60
	Nominal voltage 110...130 V AC/DC	S800-UVR130
	Nominal voltage 220...250 V AC/DC	S800-UVR250

For additional accessories, please refer to the MCB main catalog.

## Trip curves

Trip curves are essential for circuit protection by MCBs. With 5 different trip curves, MCBs from ABB provide the highest safety and protection for all types of applications and loads.

### Z Curve

- $2 \times I_n < I_{\text{Tripp}} < 3 \times I_n$  (AC)
- $2 \times I_n < I_{\text{Tripp}} < 4.5 \times I_n$  (DC)

### B Curve

- $3 \times I_n < I_{\text{Tripp}} < 5 \times I_n$  (AC)
- $4 \times I_n < I_{\text{Tripp}} < 7 \times I_n$  (DC)

### C Curve

- $5 \times I_n < I_{\text{Tripp}} < 10 \times I_n$  (AC)
- $7 \times I_n < I_{\text{Tripp}} < 15 \times I_n$  (DC)

### D Curve

- $10 \times I_n < I_{\text{Tripp}} < 20 \times I_n$  (AC)
- $10 \times I_n < I_{\text{Tripp}} < 21 \times I_n$  (DC)

### K Curve

- $10 \times I_n < I_{\text{Tripp}} < 14 \times I_n$  (AC)
- $10 \times I_n < I_{\text{Tripp}} < 22.4 \times I_n$  (DC)

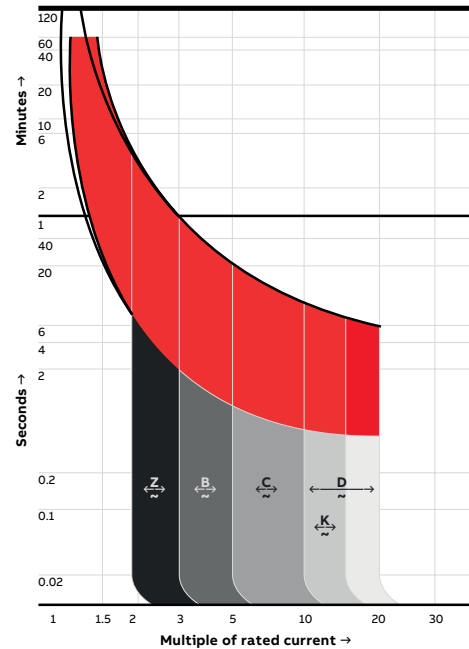





—

**ABB Inc.**

Electrification business  
305 Gregson Dr.  
Cary, NC 27511  
[electrification.us.abb.com](http://electrification.us.abb.com)

Customer Service: 800-816-7809  
7:00 a.m. - 5:30 p.m., CST, Monday-Friday  
[elec\\_custserv@us.abb.com](mailto:elec_custserv@us.abb.com)

Technical Support: 888-385-1221, Option 1  
7:00 a.m. - 5:00 p.m., CST, Monday-Friday  
[lvps.support@us.abb.com](mailto:lvps.support@us.abb.com)

—

We reserve the right to make technical changes or modify the contents of this document without prior notice. With regard to purchase orders and/or contracts, the agreed particulars shall prevail. ABB Inc. does not accept any responsibility whatsoever for potential errors or possible lack of information in this document.

We reserve all rights in this document and in the subject matter and illustrations contained therein. Any reproduction or utilization of its contents – in whole or in parts – is forbidden without prior written consent of ABB Inc.

© Copyright 2020 ABB. All rights reserved.